





EEPS-APP

INSTALLATION

INDOOR

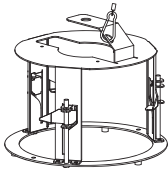
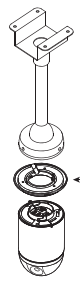
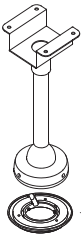
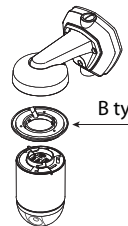
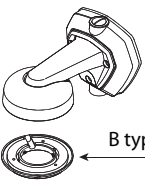
Model Select	Mount Type
Indoor Surface Mount 	
In-ceiling mount 	EEH-FC 
Indoor Ceiling Mount 	MB-302(300mm) or MB-352(500mm) 
Indoor Wall mount 	MB-301 

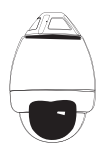
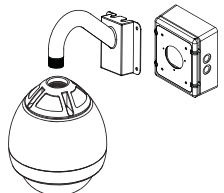
OUTDOOR

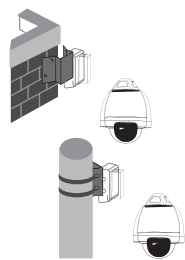
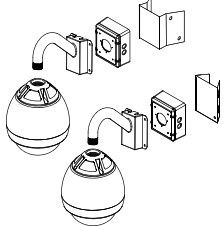
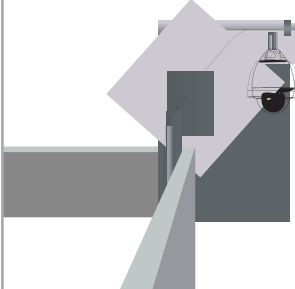
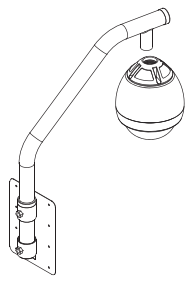
Model Select	Mount Type
Outdoor Wall Mount 	EEH-160F1C, EEW-200 and IB-100 
Outdoor Ceiling Mount 	EEH-160F1C and MB-200(300mm) or MB-250(500mm) 
Outdoor Corner & Pole Mount 	EEH-160F1C, EEW-200, EEIB-100 and MCA-100 or MPA-100 
Outdoor Parapet Mount 	EEH-160F1C and MB-600 

EEPS-APP

APPLICATIONS

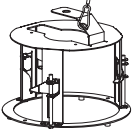
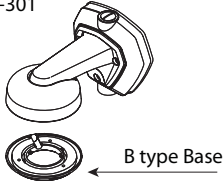
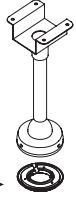

INDOOR

Item	In-ceiling Mount Housing	Wall Bracket	Ceiling Plate Pipe Adaptor
Model Name	EEH-FC	MB-301	MB-302(300mm) MB-352(500mm)
Image			
Description	<ul style="list-style-type: none"> - Steel body - Unit : 0.4Kg - Cool gray color 	<ul style="list-style-type: none"> - Aluminum body - Unit : 1.0Kg - Cool gray / Black / Silver 	<ul style="list-style-type: none"> - Aluminum & Steel body - Unit : 1.6Kg - Cool gray color

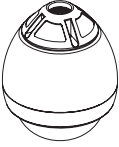
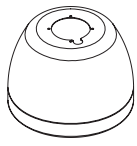
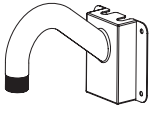
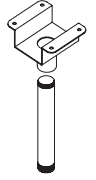
OUTDOOR

Item	Outdoor Housing with Flange	Sun Visor	Wall Pipe Plate	Mount Bracket
Model Name	EEH-160F1C	EEH-SV	EEW-200	MB-200(300mm) MB-250(500mm)
Image				
Description	<ul style="list-style-type: none"> - Aluminum body - Unit : 3.1Kg - Cool gray color 	<ul style="list-style-type: none"> - Aluminum body - Unit : 0.6Kg - Cool gray color 	<ul style="list-style-type: none"> - Steel body - Unit : 3.1Kg - Cool gray color 	<ul style="list-style-type: none"> - Steel body - Unit : 1.4Kg - Cool gray color

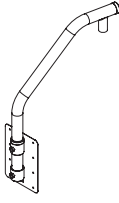
ENVIRONMENTAL

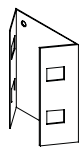
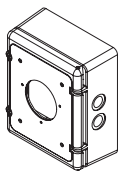
Item	Mount Bracket	Mounting Corner Adaptor	Mounting Pole Adaptor	Installation Box
Model Name	MB-600	MCA-100	MPA-100	IB-100
Image				
Description	<ul style="list-style-type: none"> - Stainless steel(SUS) body - Unit : 5.2Kg - Cool Gray color - Maximum load : 20Kg - Dimensions : 890x650 (Arm) - 250x350 (Mount plate) 	<ul style="list-style-type: none"> - Steel body - Unit : 1.3Kga - Cool gray color 	<ul style="list-style-type: none"> - Steel body - Unit : 0.7Kg - Cool gray color 	<ul style="list-style-type: none"> - Aluminum body - Unit : 5.0Kg - Cool gray / Black