

EEM-21/41

Mini Vandal Dome Camera

- ❖ NEXT-chip
- ❖ DNR
- ❖ D/N Support
- ❖ E-mark



SPECIFICATIONS

MODEL	EEM-21/41N	EEM-21/41P
Image Sensor	1/3" Type Interline Sony Super HAD CCD	
Effective Pixels	380K	440K
Scanning System	2 : 1 Interlace	
Scanning Frequency	59.94Hz	50Hz
Resolution	550TV Lines	
Shutter Speed	Auto / Fixed / Manual	
S/N Ratio	More than 48dB	
Sync.System	Internal	
White Balance	ATW / AWB / Fixed / Manual	
OSD	Built - in	
Backlight Compensation	BLC / OFF	
D&N	Auto / B/W / Color	
P.Masking	On / OFF 3 Zone	
Min.Illumination	0.05 Lux (AGC ON)	
Lens	Fixed 3.6mm	
Video Output	1.0Vp-p, 75 ohm composite	
Power Supply	12V DC \pm 10%	
Power Consumption	200mA	
Operating Temp.	-10°C ~ 50°C	
Operating Humidity	0%RH ~ 80%RH	
Weight	170g (Surface Mount Type) / 200g (Fluch Mount Type)	

FEATURES

- 1/3" Type Interline Sony Super HAD CCD
- High Resolution of 550TV Lines
- Day&Night Capability (Digital Day&Night)
- 3.6mm Fixed Lens
- IP67 rating, Aluminum Diecasting Rugged Vandal Proof Camera
- Wall or Ceiling Mounting through internal 3-Axis camera bracket
- Surface or Flush Mounting available
- Excellent Auto Tracking White-Balance
- Easy operation by On Screen Display
- Dome size : 57 \varnothing
- E-mark for Vehicle Application

DIMENSIONS

Unit : mm

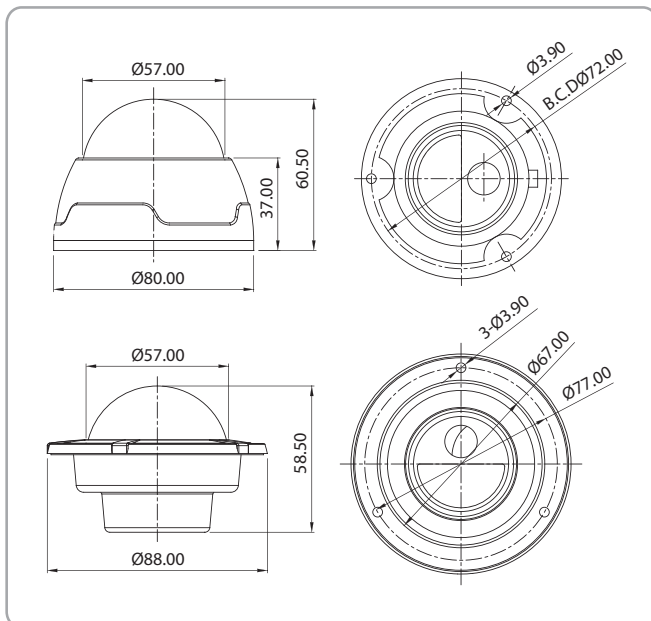

CONNECTIONS

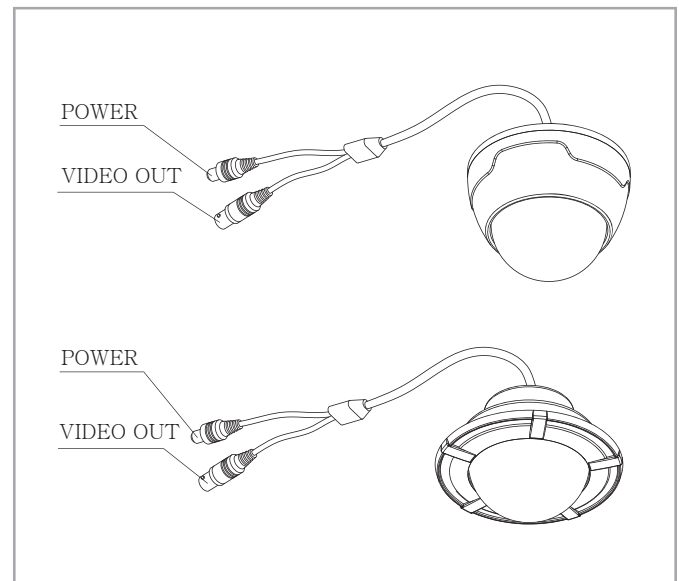

EEM-APP

Mini Vandal Dome Camera

APPLICATION

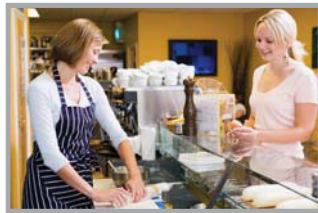

Kabel-Distanzring



Unit : mm

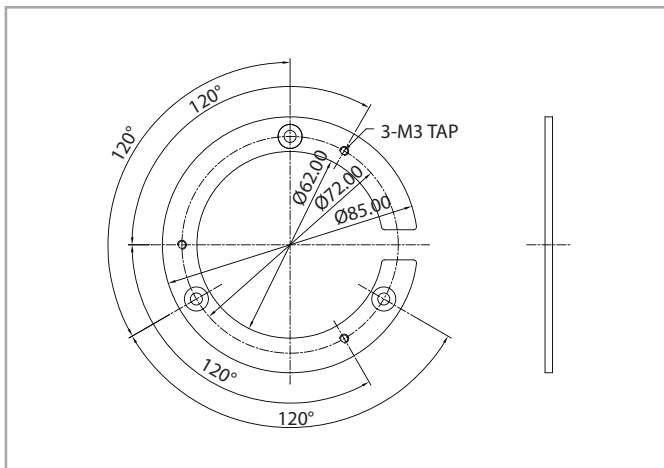

Aufbaugehäuse



Unit : mm

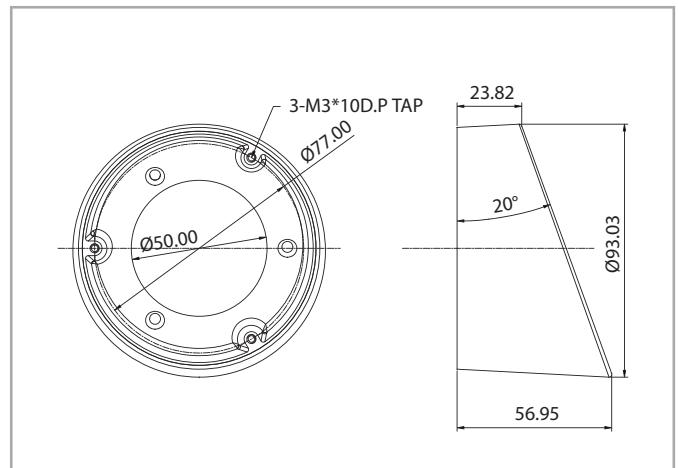

OSD Bedienung EEM-327/326

